

INSTALLATION OPERATION MAINTENANCE

Customer Property — Contains wiring, service, and operation information. Please retain.

TC-IOM-4G 18-AB60D16-7

Library	Service Literature
Product Section	Unitary
Product	Rooftop Lt. Comm.
Model	TC
Literature Type	Installation/ Oper/ Maint
Sequence	4G
Date	August 1998
File No.	SV-UN-RT-TC-IOM-4G 8/98
Supersedes	TC-IOM-4F

Models: **(60 Hz)** **(50 Hz)**
 TC*102-301 TC*085-250

Packaged Electric/Electric 8-1/2 thru 25 Ton

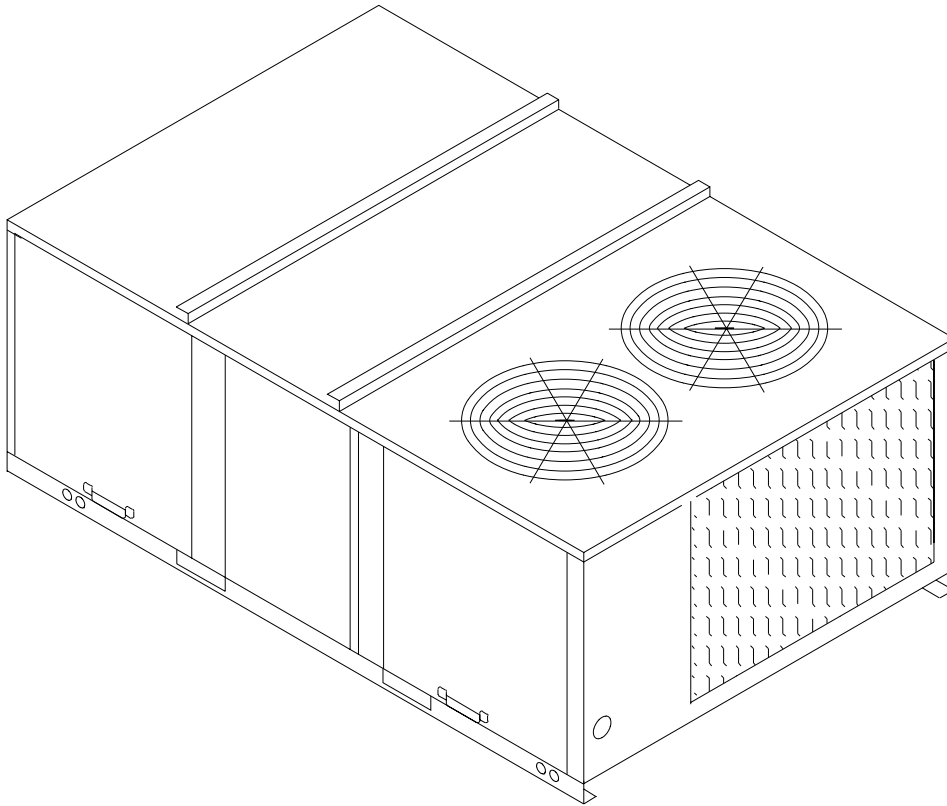

IMPORTANT NOTE: All phases of this installation must comply with the **NATIONAL, STATE & LOCAL CODES**. In addition to local codes, the installation must conform with National Electric Code **-ANSI/NFPA NO. 70 LATEST REVISION**. These units are equipped with an electronic unit control processor, (UCP) that provides service functions which are significantly different from conventional units. Refer to the **TEST MODES** and **START-UP PROCEDURES** before attempting to operate or perform maintenance on this unit.

Since the manufacturer has a policy of continuous product improvement, it reserves the right to change specifications and design without notice. The installation and servicing of the equipment referred to in this booklet should be done by qualified, experienced technicians.

Table of Contents

Inspection	2	Placing and Rigging	8
Module Names	3	Attaching Downflow Ductwork to Roof Curb	10
Unit Features	3	Filter Installation	10
ZSM Mode	3	Evaporator Fan Adjustment	11
Return Air Smoke Detector	4	Interconnecting Diagram	13
Auto Test Mode	5	Compressors	14
Resistance Test Mode	5	Pre-Start Quick Check List	14
Unit Dimensions	6	Power-up Initialization	15
Curb Dimensions	7	Unitary Control Processor (UCP)	15
Installation	8	Switch Settings for Cycle Timing	15
Unit Support	8	Final Installation Checklist	16
Location and Clearances	8		

Read this manual carefully before attempting to install, operate or perform maintenance on this unit. Installation and maintenance must be performed by qualified service technicians except where noted.

⚠ WARNING: *Bodily injury can result from high voltage electrical components and fast moving fan drives. For protection from these inherent hazards during installation and servicing, the electrical supply must be turned off. If operating checks must be performed with the unit operating, it is the technician's responsibility to recognize these hazards and proceed safely.*

⚠ WARNING: *All power legs to the electrical components may not be broken by contactors. See the wiring diagram on the unit control box cover.*

Before starting the compressor, the crankcase heaters should be energized for eight hours.

Exception - Circuit #1 on 181 and 211 units and both circuits on the 200, 240 thru 301 units are not equipped with crankcase heaters.

Note: *"Warnings" and "Cautions" appear at appropriate places in this manual. Your personal safety and the proper operation of this machine require that you follow them carefully. The manufacturer assumes no liability for installations or servicing performed by unqualified personnel.*

Inspection

1. Check for damage after unit is unloaded. Report promptly, to the carrier, any damage found to unit. Do not drop unit.
2. Check unit nameplate to determine if unit is correct for application intended. Power supply must be adequate for the unit and all accessories.
3. Check to be sure the refrigerant charge has been retained during shipment. Access to 1/4" flare pressure taps may be gained by removing compressor compartment access panel.

⚠ WARNING: *UNIT CONTAINS AN HCFC (R-22) REFRIGERANT*

Section 608 paragraph C of the 1990 Clean Air Act states: Effective July 1, 1992 it shall be unlawful for any person, in the course of maintaining, servicing, repairing, or disposing of an air conditioning system, to knowingly vent or release any CFC or HCFC refrigerant. Minimal releases (air purges of refrigerant hoses) associated with good faith attempts to recapture or recycle are exempt from the ban on venting.

MODULE NAMES

UCP - Unitary Control Processor (standard component)
This is the heart of the system. The computer program resides in this module. The minimum configuration will include the **UCP** and one of the zone sensor modules.

ZSM - Zone Sensor Module (accessory component)
Replaces thermostat, provides operator controls and the zone temperature sensor for the **UCP**. A complete line of **ZSMs** is available with various combinations of features. A zone sensor module, or a CTI (BAYCTHI001) and generic control is required for each system.

UEM - Unitary Economizer Module (standard component on economizer accessory). This module provides the hardware necessary to connect the economizer accessory to the **UCP**.

TCI - Communication Interface. This interface is required to connect the system to an ICS BUILDING MANAGEMENT, i.e. - Tracker or Tracer. system.

CTI - Conventional Thermostat Interface (BAYCTHI001 accessory component.) This module can be used in special applications that require the installation of select electro-mechanical thermostats to interface with the **UCP**, instead of using a zone sensor module (**ZSM**)

UNIT FEATURES

Self-test/Auto-configuration

At power-up, the system will perform a series of tests to verify correct operation and configure itself automatically, based on the unit wiring harness.

Cooling Minimum ON/OFF times

To enhance compressor reliability, a minimum of 3 minutes ON/OFF time has been implemented in the software. Any time power is applied or re-applied (e.g. after a power failure), the 3 minutes minimum OFF time is enforced to prevent short cycling a compressor.

Lead-Lag

A selectable configuration within the UCP which alternates the starting of the compressors between the two refrigeration circuits. To enable the Lead/Lag function, cut wire 52F (PR) which is connected to terminal J1-7 at the UCP. Refer to the unit wiring diagram. Each time the request for cooling is satisfied, the designated lead compressor switches. Upon Powerup Initialization, the control will default to the number one compressor. When a Conventional Thermostat Interface (CTI) is used, Lead/Lag is functional except during the test mode.

Zone Temperature Sensor

The zone temperature sensor provides the zone temperature sensing function to the **UCP**.

ZSM MODE

HEAT - Heat functions only enabled.

AUTO - Auto-changeover between Cooling mode and Heating mode as required by zone load.(On some models)

OFF - No heating or cooling functions

COOL - Cooling functions only, including economizer function enabled.

FAN SETTINGS

FAN AUTO - Fan is enabled only when heating or cooling functions are required.

FAN ON - Fan is enabled at all times. This setting is used when minimum ventilation is required.

Option Remote Panel Zone Sensors Indicator Lights

SYS-ON

Indicates that power is applied to the unit and the UCP is functioning correctly. This indicator will flash at a 1 second rate to indicate operation of one of the test modes.

HEAT

Indicates that at least one stage of heat is ON. This indicator will flash at a 1 second rate to indicate a heat failure .

COOL

Indicates that cooling is active. This could be economizing and/or compressor cooling. This indicator will flash at a 1 second rate to indicate a cool failure. Sources of cool failure include high pressure controls if present and zone sensor failures.

SERVICE

Indicates that a problem exists in the supply air stream. Could be dirty filters, broken drive belt or other functions depending on what sensors or switches are installed on the fan/filter status input.

Return Air Smoke Detector

Important: If this unit is equipped with an economizer, it will be necessary for the installer to complete the hook-up of the return air smoke detector. Refer to the installation instructions for the return air smoke detector provided in the literature package for the step-by-step procedure to complete this hook-up.

Important: The return air smoke detector is designed to shut off the unit if smoke is sensed in the return air stream. This function is performed by sampling the airflow entering the unit at the return air opening. Follow the instructions provided below to assure that the airflow through the unit is sufficient for adequate sampling. Failure to follow these instructions will prevent the smoke detector from performing its design function.

Important: Airflow through the unit is affected by the amount of dirt and debris accumulated on the indoor coil and filters. To insure that the airflow through the unit is adequate for proper sampling by the return air smoke detector, more frequent replacing and/or cleaning of these components is required.

Important: Periodic checks and maintenance procedures must be performed on the smoke detector to insure that it will function properly. For detailed instructions concerning these checks and procedures, refer to the appropriate section(s) of the smoke detector Installation and Maintenance Instructions provided with the literature package for this unit.

In order for the return air smoke detector to properly sense smoke in the return air stream, the air velocity entering the unit must be between 500 and 4000 feet per minute. Equipment covered in this manual will develop an airflow velocity that falls within these limits over the entire airflow range specified in the evaporator fan performance tables.

There are certain models however, if operated at low airflow, will not develop an airflow velocity that falls within the required 500 to 4000 feet per minute range. For these models, the design airflow shall be greater than or equal to the minimum specified in the table provided below.

Unit Model Number	Minimum Allowable Airflow with Return Air Smoke Detector
TCD103	3400 CFM
TCD121	4100 CFM
TCD181	5300 CFM

TEST MODE PROCEDURE

Operating the unit from the roof using the test mode.

WARNING: *When operating the unit in the test mode, the evaporator access panel and the control box cover, must be closed. Failure to ensure that the evaporator access panel and control box cover is in place could result in severe personal injury or death*

The Unitary Control Processor (UCP) has a red indicator light in the lower left corner. When power is applied to the unit the light will glow if the UCP is functioning correctly. If the system is placed in the test mode the light will blink continuously.

Note: *The control box cover has a small peep hole, located in the lower left hand corner. The red indicator light on the UCP can be seen through this peep hole. Do not remove the control box cover while the unit power is connected.*

Step Test Mode

The step test mode is initiated by shorting across the "TEST" terminals, marked test 1 and test 2 on the unit's low voltage terminal strip (LTB), for two (2) to three (3) seconds and then removing the short.

When the test mode is initiated, the light on the UCP will blink and the system will begin the first test step, and turn on the indoor fan. (See test mode table)

To continue to the next step, reapply the short across the test terminals for 2 to 3 seconds.

The unit may be left in any test step for up to one hour. If allowed to remain in any test step for more than one hour, the test mode will terminate and control will revert to the zone sensor. As you continue to apply and remove the short across the test terminals, the unit will move through the steps according to the table below.

To terminate the test mode, cycle the unit power at the unit disconnect or continue stepping through the modes until the UCP's indicator light glows constantly.

Test Mode Table

Step	Mode	Fan	Econ	C1	C2	Heat 1	Heat 2	Heat 3	Defrost	Em Heat
1	Fan On	On	Min	Off	Off	Off	Off	Off	Off	Off
2*	Econ	On	Open	Off	Off	Off	Off	Off	Off	Off
3	Cool 1	On	Min	On	Off	Off	Off	Off	Off	Off
4	Cool 2	On	Min	On	On	Off	Off	Off	Off	Off
5	Heat1	On	Min	Off	Off	On	Off	Off	Off	Off
6*	Heat 2	On	Min	Off	Off	On	On	Off	Off	Off
7*	Heat 3	(Not Applicable on Electric/Electric or Gas Units)								
8**	Defrost	(Not Applicable on Electric/Electric or Gas Units)								
9**	Em Heat	(Not Applicable on Electric/Electric or Gas Units)								

* With Optional Accessory

** With Heat Pump

Note: Steps for optional accessories and modes not present in unit, will be skipped.

Resistance Valves Chart

STEP	MODE	Ohms
1	FAN ON	2.2K
2*	ECONOMIZER	3.3K
3	COOL 1	4.7K
4	COOL 2	6.8K
5	HEAT 1	10K
6*	HEAT 2	15K
7*	HEAT 3	22K
8**	DEFROST	33K
9**	EM HEAT	47K

* With Optional Accessory

** With Heat Pumps

Note: Steps 7, 8 & 9 are not applicable on Electric/Electric or Gas Units

Auto Test Mode

—The auto test mode is initiated by installing a jumper between terminals marked TEST 1 and TEST 2 on the LTB. The unit will start in step 1 and cycle through the test steps one time, changing every 30 seconds.

—When the test mode is initiated, the light on the UCP will blink and the system will begin the first test step, and turn on the indoor fan. (See test mode table)

—At the end of the auto test mode, the indicator light will glow constantly and control will revert to the zone sensor.

—The unit can be left in any one of the test steps, by removing the jumper. It will remain in this step for up to one hour. If allowed to remain in any test step for more than one hour, the test mode will terminate and control will revert to the zone sensor.

— To terminate the test mode, cycle the unit power at the unit disconnect.

Resistance Test Mode

The resistance test mode is Initiated by applying the appropriate resistance value across the "Test" terminals marked TEST 1 and TEST 2 on the LTB.

—When the test mode is initiated, the light on the UCP will blink and the system will begin the test step selected by the resistance being applied across the test terminals. (See test mode table)

—The resistance values are indicated in the Resistance Value Chart below.

—After selecting the desired test step, and applying the appropriate resistance across the test terminals, the unit will start.

—The unit can be left in this step for up to one hour. If allowed to remain in any test step for more than one hour, the test mode will terminate and control will revert to the zone sensor.

—To terminate the test mode, remove the resistance, and cycle the unit power at the unit disconnect.

Dimensional Data

Unit Dimensions

UNITS	A	B	C	D	E	F	G	H	J	K
TC*100B,103C TC*120B,125C TC*150C	63 5/16	94 5/16	13/16	49	28 5/8	2 3/16	8 3/8	39 3/8	6 13/16	2
TC*085C,100C TC*102C,120C	49 9/16	88 3/8	N/A	45 1/2	25 11/16	1 13/16	6 3/4	42 11/16	6 3/8	2
TC*121C,151C TC*155B,175C TC*180B,210C	71 5/16	107 5/16	13/16	50 1/8	29 5/16	2 11/16	8 3/8	48 3/8	6 5/8	2
TC*181C,200B TC*240B,250B TC*300B,301C	85 5/16	122 5/16	13/16	54	33 3/16	2 11/16	8 15/16	64 1/2	6 13/16	3

* Downflow or Horizontal

(TCD180 Illustrated)

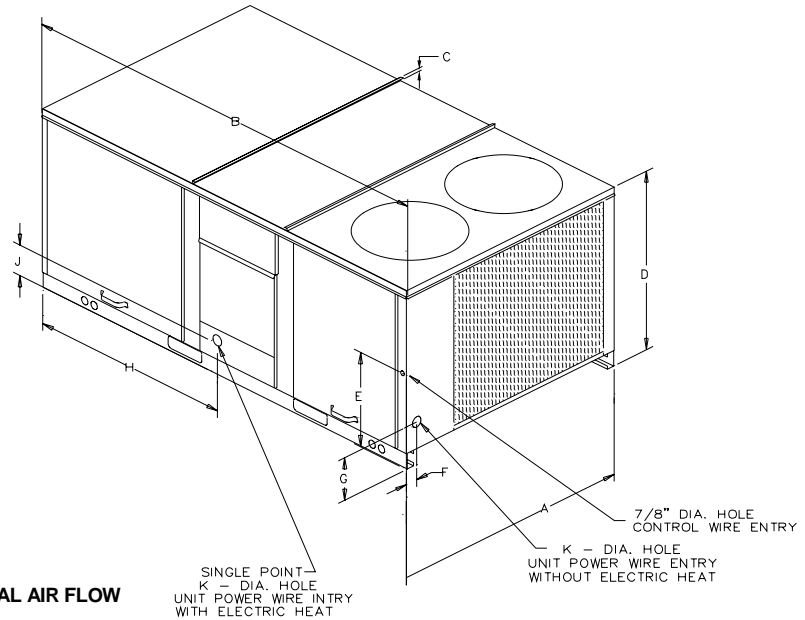

HORIZONTAL UNIT

REAR VIEW SHOWING DUCT OPENINGS FOR HORIZONTAL AIR FLOW

UNITS	A	B	C	D	E	F
TC*100B,103C TC*120B,125B TC*150C	22 1/2	18	17 3/16	2	3 15/16	41 7/16
TC*085C,100C, TC*102C,120C	16	16 1/4	20 1/16	3	6 3/8	36
TC*121C,151C TC*155B,180B TC*175C,210C	26 1/2	19 9/16	24 9/16	2	3 15/16	42 1/2
TC*181C,200B TC*211C,240B TC*241C,250B TC*300B,301C	26 1/2	24 1/16	27 9/16	2	3 15/16	46 7/16

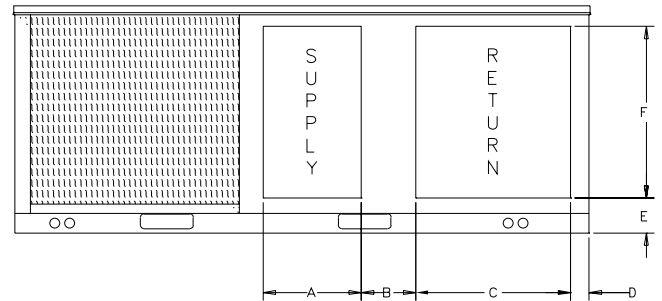

DOWNFLOW UNIT

TOP VIEW SHOWING DUCT OPENINGS IN THE BASE

UNITS	A	B	C	D	E
TC*100B,103C TC*120B,125C TC*150C	22 7/16	14 1/2	17 11/16	54 13/16	47 3/16
TC*085C,100C TC*102C,120C	15 3/16	22 1/2	12 15/16	42 7/8	35 1/4
TC*121C,151C TC*155B,175C TC*180B,210C	26 7/16	22 1/2	18 11/16	62 7/16	54 11/16
TC*181C,200B TC*240B,250B TC*300B,301C	26 7/16	28 3/4	19 15/16	76 5/16	68 11/16

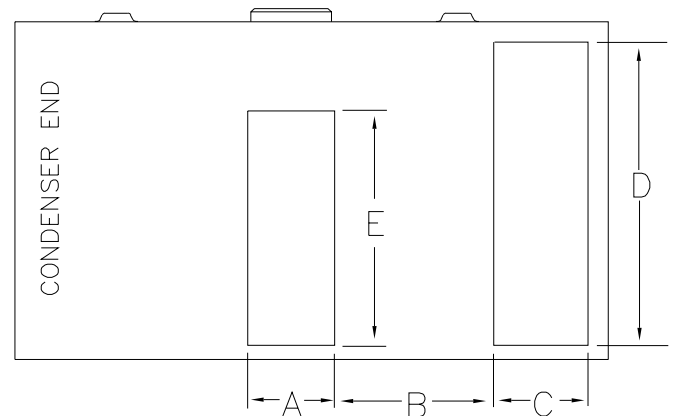

Figure	UNITS	A	B	C	D	E	F	G	H	J	K	L	M	N	P
1A	TC*103C,125C	59 1/8	55 7/16	1 13/16	19 1/8	9 7/8	24 1/2	88 15/16	59 7/16	89 1/4	2	14 1/16	1	8 1/16	47 7/16
1A	TC*150C														
1B	TC*085C,100C, 1B TC*102C,120C	81 1/4	46 1/16	14	14 3/8	17 1/4	18 1/4	42 3/8	2	1 13/16	36 3/16	81 5/8	46 3/8	N/A	N/A
1A	TC*121C,151C	66 5/8	63	1 13/16	20 7/8	17 1/8	28 1/2	101 7/8	67	102 1/4	2	14 1/16	1	7 1/2	55 1/2
1A	TC*155B,180B														
1A	TC*175C,210C														
1A	TC*181C,200B	80 5/8	77	1 13/16	22 1/4	23 1/4	28 9/16	116 13/16	81	117 3/16	2	14 1/16	1	7 1/2	69 1/2
1A	TC*211C,240B														
1A	TC*241C,250B														
1A	TC*300B,301C														

* G Dimension represents the distance from the top of the curb to the duct flange.

Figure 1A

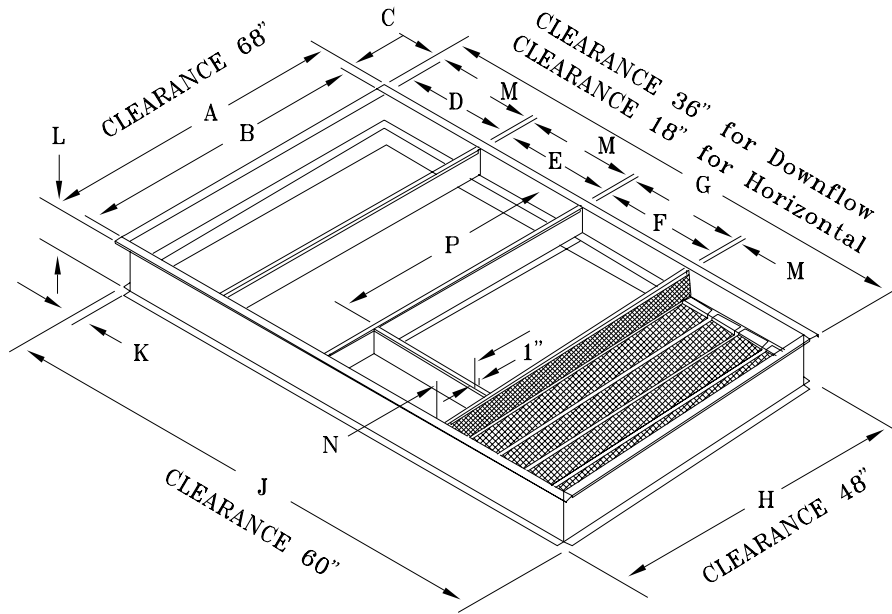
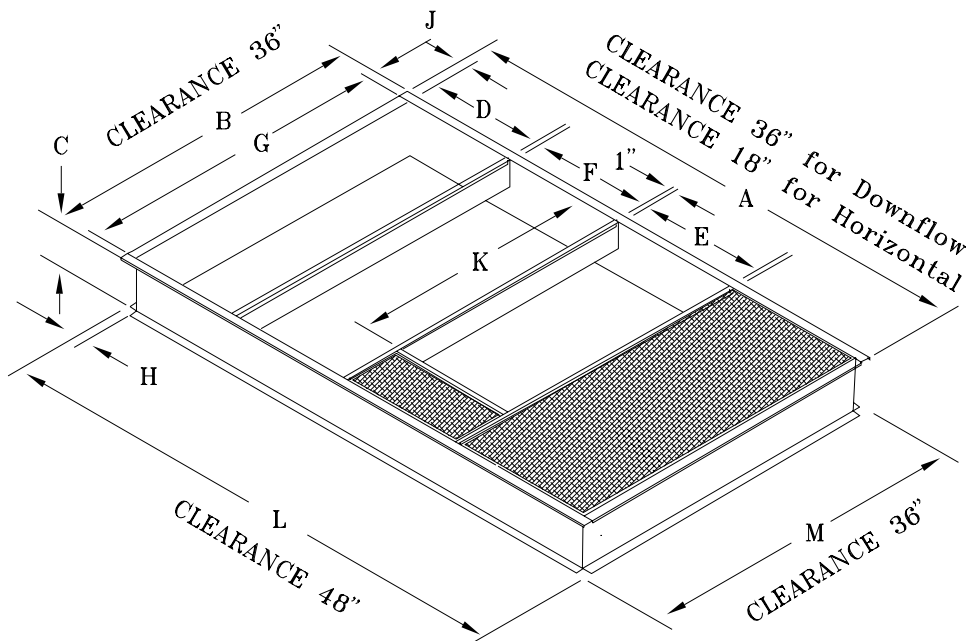

Figure 1B



INSTALLATION

Location and Recommendations

Unit Support

If unit is to be roof mounted check building codes for weight distribution requirements. Refer to accessory roof curb mounting instructions. Check unit nameplate for supply voltage required. Determine if adequate electrical power is available. Refer to specification sheet.

Location and Clearances

Installation of unit should conform to local building codes, and the National Electrical Code. Canadian installations must conform to CSA and local codes.

Select a location that will permit unobstructed airflow into the condenser coil and away from the fan discharge. Suggested airflow clearances and service clearances are given in Figure 1A and 1B .

Placing and Rigging

Note: Before attempting to rig the unit, remove the fork lift pockets located on the condenser end of the unit.

Rig the unit using either belt or cable slings. The sling eyelet must be placed through the lifting holes in the base rail of the unit. The point where the slings meet the lifting eyelet should be at least 6 feet above the unit. Use spreader bars to prevent excessive pressure on the top of the unit during lifting. Figure 2 shows the unit center of gravity.

IMPORTANT: The use of "spreader bars" is required when hoisting the unit (prevents damage to sides and top). Top crating can be used as spreader bars.

Figure 2

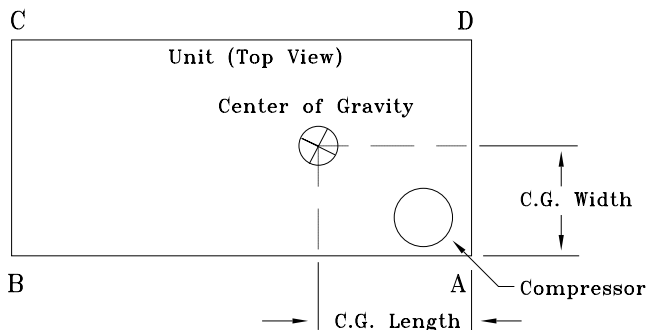

Mounting Unit on Roof

Downflow units should be mounted on a roof curb when possible. When installing the unit on the roof curb, follow the installation instructions accompanying the roof curb kit. On new roofs, the curb should be welded directly to the roof deck. For existing construction, nailers must be installed under the curb if welding is not possible. Be sure to attach the downflow ductwork to the curb before setting unit in place. See Figure 3A or 3B. Refer to the curb installation instructions to insure the unit will be level.

When installing the unit, it must be level to insure proper condensate flow from the unit drain pan. The maximum pitch of the unit down from the condensate drain of the unit is **1/16 inch per foot**.

Slab Mount

For ground level installation, the unit base should be adequately supported and hold the unit near level. The installation must meet the guidelines set forth in local codes.

Table 1
Corner weights & Center of Gravity

Unit Description	Net Weight	Corner Weights (lbs.) (See Note 1)				Center of Gravity (in.)	
		A	B	C	D	Length	Width
TC*085C	857	298	217	144	197	37	20
TC*102C	857	298	217	144	197	37	20
TC*103C	1094	353	291	203	246	43	26
TC*100C	879	302	225	150	202	38	20
TC*120C	879	302	225	150	202	38	20
TC*121C	1385	468	357	242	318	46	29
TC*125C	1161	389	307	205	260	42	26
TC*150C	1161	389	307	205	260	42	26
TC*151C	1408	474	349	248	337	45	30
TC*155B	1371	482	350	227	312	45	28
TC*180B	1371	482	350	227	312	45	28
TC*181C	1850	635	464	317	434	52	35
TC*175C	1452	500	378	247	327	46	28
TC*210C	1452	500	378	247	327	46	28
TC*211C	1921	643	495	341	442	53	35
TC*200B	1850	654	487	303	406	52	33
TC*240B	1850	654	487	303	406	52	33
TC*241C	2011	692	523	343	453	53	34
TC*250B	1906	661	507	320	418	53	33
TC*300B	1906	661	507	320	418	53	33
TC*301C	2016	695	524	343	454	53	34

*Downflow or Horizontal

Note: Corner weights are given for information only. Unit is to be supported continuously by curb or equivalent frame support.

Duct Dimensions

UNITS	A	B	C	D	E	F	G
TC*103C ¹ ,125C ¹ TC*150C ¹	51 7/8	16 3/16	44 1/2	22 5/16	1	14 1/16	7 7/16
TC*085C ² ,100C ² , TC*102C ² ,120C ²	41 1/4	13 3/4	35 5/8	16 7/8	1	14 1/16	N/A
TC*121C ¹ ,151C ¹ TC*155B ¹ ,180B ¹ TC*175C ¹ ,210C ¹	59 7/16	17 7/8	52 1/2	26 5/16	1	14 1/16	7 7/16
TC*181C ¹ ,200B ¹ TC*211C ¹ ,240B ¹ TC*241C ¹ ,250B ¹ TC*300B ¹ ,301C ¹	73 7/16	19 5/16	66 1/2	26 5/16	1	14 1/16	7 7/16

¹ - Use Figure 3A

² - Use Figure 3B

* G Dimension represents the distance from the top of the curb to the duct flange.

Figure 3A

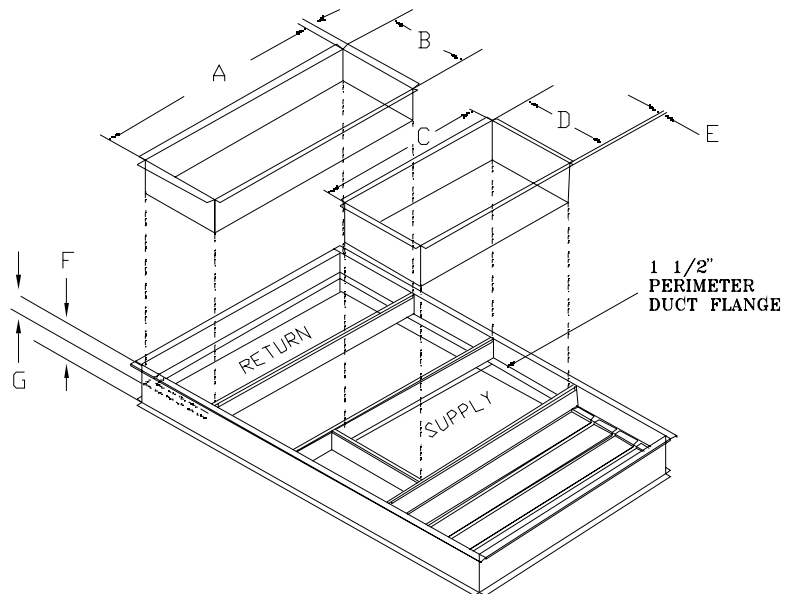
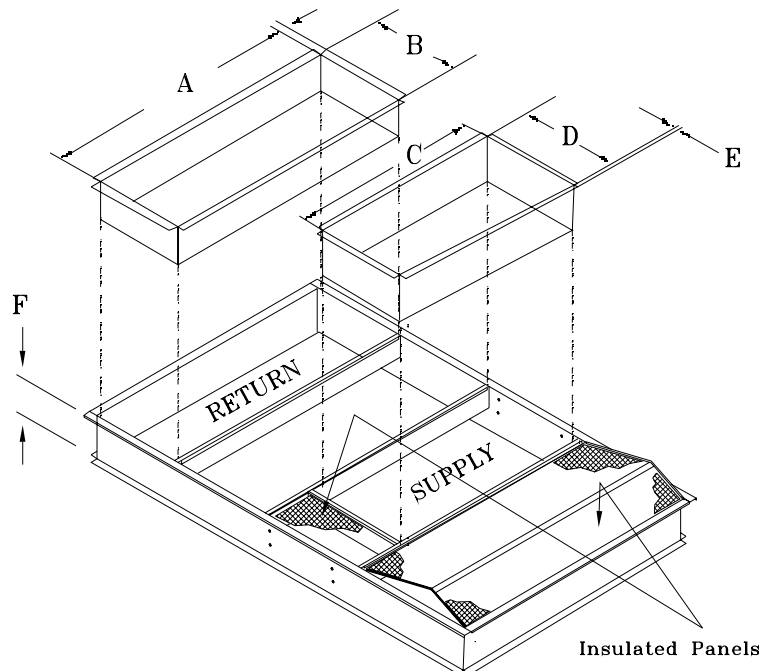

Figure 3B



Ductwork

Attaching Downflow Ductwork to Roof Curb

Supply and return openings have curb flanges provided for easy duct installation.

Note: Ductwork sleeves must be attached to the curb flanges before the unit is set into place. See Figure 3A and 3B for duct connections and dimensions.

The following warning complies with State of California law, Proposition 65.

▲ WARNING: This product contains fiberglass wool insulation! Fiberglass dust and ceramic fibers are believed by the state of California to cause cancer through inhalation. Glasswool fibers may also cause respiratory, skin, or eye irritation. See page 16 for precautionary and first aid measures.

Guidelines for ductwork construction:

- Connections to the unit should be made with three-inch canvas connectors to minimize noise and vibration transmission.
- Elbows with turning vanes or splitters are recommended to minimize air noise and resistance.
- The first elbow in the ductwork leaving the unit should be no closer than two feet from the unit, to minimize noise and resistance.

Attaching Horizontal Ductwork to Unit

- All conditioned air ductwork should be insulated to minimize heating and cooling duct losses. Use minimum of 2" of insulation with a vapor barrier. The outside ductwork must be weather proofed between the unit and the building.
- When attaching ductwork to a horizontal unit, provide a flexible water tight connection to prevent noise transmission from the unit to the ducts.

Note: Do not draw the canvas connectors taut between the unit and ducts. See dimensional data for duct connections.

Condensate Drain Piping

A 3/4 inch PVC condensate drain connection is provided on the YC, TC*085 - 120C units only. A 1 inch NPT female condensate drain connection is provided on all other units.

Follow local codes and standard piping practices when running the drain line. Install a trap and be sure to fill with water before starting the unit. Pitch the line downward, away from the unit; avoid long, level, horizontal runs. Refer to Figure 4.

Figure 4

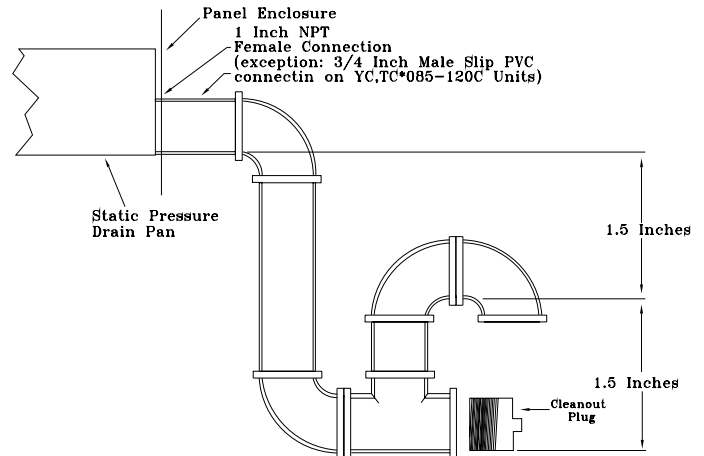

Filter Installation

To gain access to filters, remove the evaporator fan access panel. Each unit ships with 2 inch filters. Number and size of filters is determined by size and configuration of the unit. Refer to the unit "Service Facts" for filter requirements.

Evaporator Fan Adjustment

Use the following procedure to determine the proper adjustment of the evaporator fan sheaves for a specific application.

1. Determine total system external static pressure (in inches water column) with accessories installed. To accomplish this:
 - a. Obtain the design airflow rate and the design external static pressure drop through the distribution system. Your sales representative or the design engineer can provide you with these values.
 - b. Using the table from unit Service Facts, add static pressure drop of the accessories installed on the unit.
 - c. Add the total accessory static pressure drop (from step 1b) to the design external static pressure. The sum of these two values is the total system external static pressure.
2. Use the table(s) in the Service Facts to find the external static pressure (in inches water column) that most closely approximates total system external static pressure. Then locate the appropriate airflow rate (in cfm) for your unit. The value obtained represents the brake horsepower for the evaporator fan motor and the fan RPM.

Important: Fan Break Horsepower (BHP) listed in the Table is the percentage range of nameplate amperage the motors will safely work within before and oversized motor is required.

3. Adjust the variable pitch pulley to increase or decrease the fan RPM as required. See Figure 6.

Figure 6

Typical fan, motor, and sheave assembly

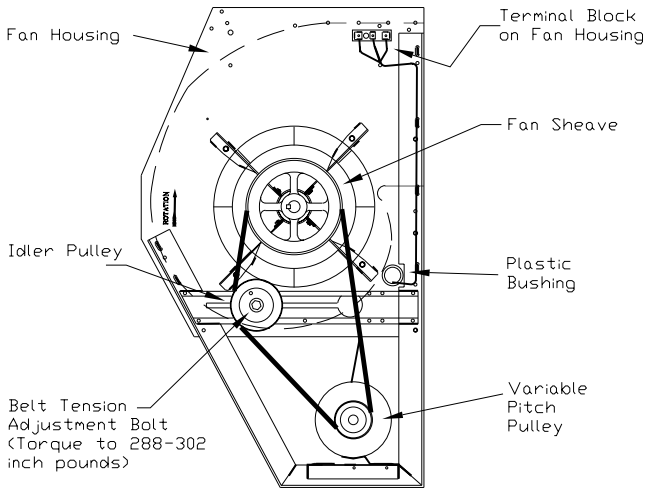

TO INCREASE CFM

Loosen the pulley adjustment set screw and turn sheave clockwise

TO DECREASE CFM

Loosen the pulley adjustment set screw and turn sheave counter-clockwise

TO INCREASE BELT TENSION

Loosen the nut (next to the idler sheave) that secures the sheave in place. With a wrench, apply pressure clockwise on the outside nut (round headed one), until tension desired is reached. While holding pressure with the tension nut, retighten the nut next to the idler sheave.

Electrical Connections

Electrical wiring and grounding must be installed in accordance with local codes and with The National Electric Code ANSI/NFPA70 Latest Revision.

Electrical Power

It is important that proper electrical power is available for the unit. Voltage variation should remain within the limits stamped on the nameplate.

Important: All 208-230 volt units are factory wired for 230 volt applications. If the power supply voltage is less than 215 VAC, refer to the unit wiring diagram pasted to the inside of the control box cover or the unit Service Facts, to convert the transformers to 208 volts.

Disconnect Switch

Provide an approved weather-proof disconnect either on the side of unit or within close proximity.

Over Current Protection

The branch circuit feeding the unit must be protected as shown on the unit rating plate.

Power Wiring

The power supply lines must be run in weather-tight conduit to the disconnect, and into the bottom of the unit control box. Provide strain relief for all conduit with suitable connectors.

Note: Units with Scroll Compressors only. Proper scroll compressor rotation is determined by main power electrical connections.(See Compressor Electrical Phasing section.)

Provide flexible conduit supports whenever vibration transmission may cause a noise problem within the building structure.

Insure all connections are made tight. (See Figure 7)

Note: For branch circuit wiring (main power supply to unit disconnect), Wire size for the length of run should be determined using the circuit ampacity found on the unit nameplate and the N.E.C..

For more than 3 current carrying conductors in a raceway or cable, see the N.E.C. for de-rating the ampacity of each conductor.

GROUNDING: THE UNIT MUST BE ELECTRICALLY GROUNDED IN ACCORDANCE WITH LOCAL CODES AND THE NATIONAL ELECTRICAL CODE.

Control Wiring (Class II)

Note about Low Voltage Transformers:

Units have intergal circuit breakers in their low voltage transformers. If the breaker trips, be sure to open the unit disconnect before attempting to reset the breaker.

Some earlier models units have a replaceable fuse mounted in the transformer. An extra fuse is taped down near the transformer. To use this replacement fuse, remove the old one by pushing in and turning counterclockwise 1/4 turn, then pull it out. To insert the new fuse, push in and turn clockwise until it stop.

CAUTION: Do not replace with a fuse of greater ampacity than 3.5 amps.

⚠ WARNING: Open and lock unit disconnect. Failure to do so could result in severe personal injury or death due to electrical shock.

Remove compressor access panel and control box panel to access transformer. Reset by pressing in on the black reset button located on the left side of the transformer.

Replace all panels before restoring power to the unit.

Important Note: The unit 24 volt transformer must not be used to power Field Installed Accessories (FIA), except for the ones that are factory supported.

Figure 7
Typical Field Wiring Diagram

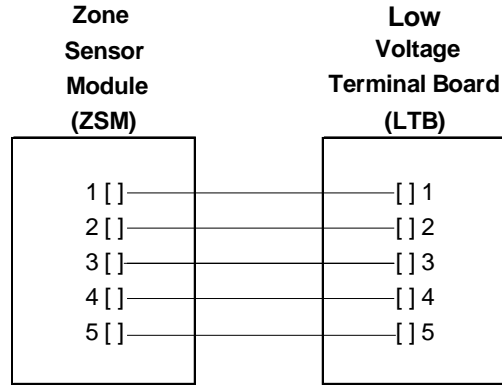
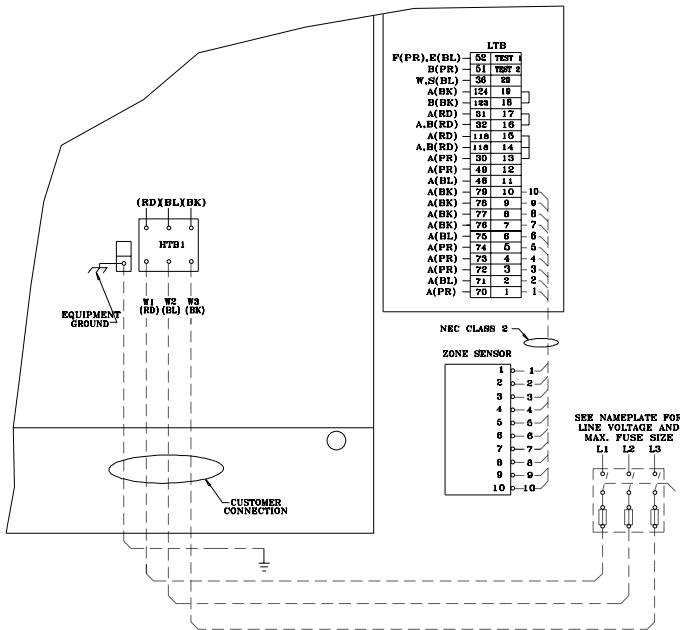

Zone Temperature Sensor and low voltage terminal designations are no longer R-W-Y-G-B etc, they are now 1-2-3 etc. Connections should be made using 1 to 1, 2 to 2, 3 to 3, and so on. See example below.

Zone Temperature Sensor Terminal Strip

Terminal #	Terminal I.D.
1	ZTEMP
2	SIGNAL COMMON
3	CSP
4	MODE
5	HSP
6	LED COMMON
7	HEAT LED
8	COOL LED
9	SYS ON LED
10	SERVICE LED

Low voltage control wiring **must not** be run in conduit with power wiring. Route low voltage (class II) colored wire from zone sensor terminals through 7/8 inch bushing in the unit. See dimensional data for control wire entry location. Make connections as shown by the appropriate low voltage wiring diagrams in Figure 8.

Zone Temperature Sensor conductors are standard thermostat wire 22 to 14 ga. The only exceptions are Tracer/Tracker installations which utilize a serial communications link and require a shielded twisted pair of conductors between the Tracer/Tracker and the (TCI) Communications Interface.

Recommended wire sizes and lengths for installing the Zone Temperature Sensor are provided in Table 4. Ensure that the wiring between the controls and the unit's termination point does not exceed two and a half (5) ohms/conductor for the length of the run. Resistance in excess of 5 ohms per conductor can cause deviation in the accuracy of the control.

Table 4.

Distance from Unit to Control	Recommended Wire Size
000 - 150 feet	22 gauge
151 - 250 feet	20 gauge
241 - 375 feet	18 gauge
386 - 600 feet	16 gauge
611 - 975 feet	14 gauge

NOTE: Do not run the electrical wires transporting DC signals in or around conduit housing high voltage wires.

Emergency Shut Down

For Emergency Shut Down, remove the jumper between LTB-16 and LTB-17 and install normally closed contacts (Open at Fault Condition). Immediate shut down will occur and the UCP will be disabled.

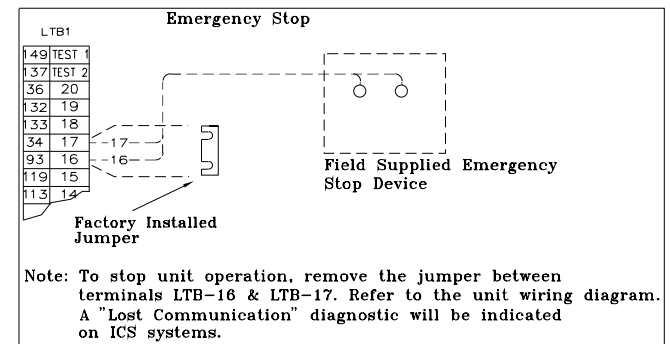

Compressor Disable

To disable Compressor #1, remove the jumper between LTB-13 and LTB-14 and install normally closed contacts (open to disable).

To disable Compressor #2, (if applicable), remove the jumper between LTB-14 and LTB-15 and install normally closed contacts (open to disable).

Figure 8
Zone Sensor Interconnecting Diagram

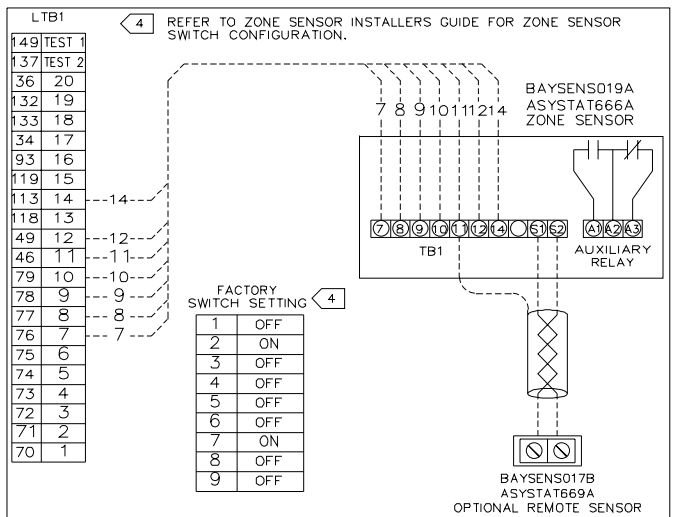
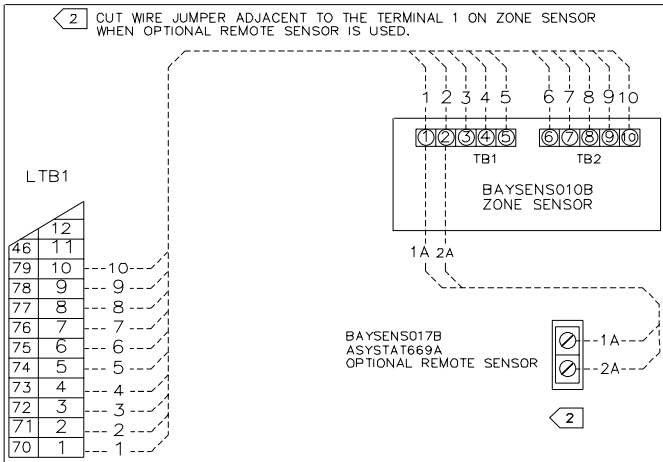
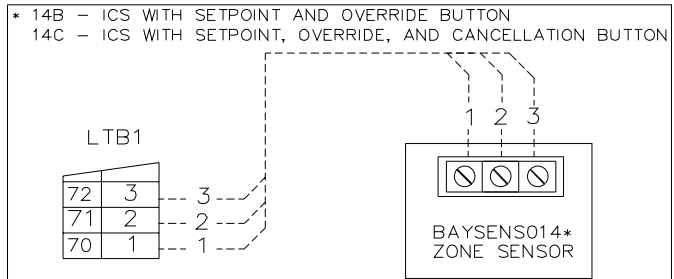
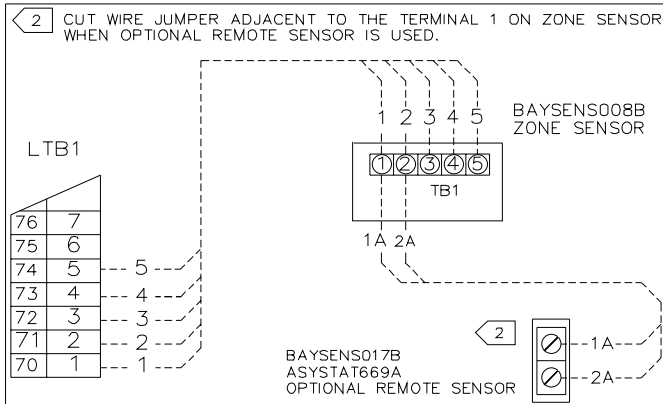
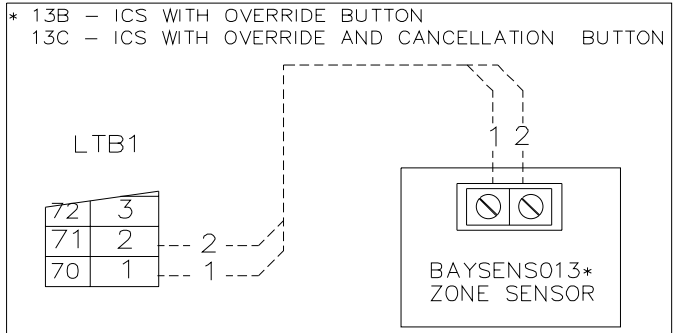
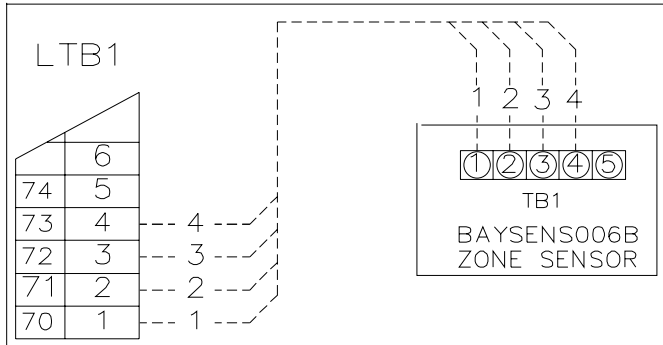

- SYSTEM CONNECTION NOTES:**
1. ALL WIRING AND DEVICES SHOWN DASHED TO BE SUPPLIED AND INSTALLED BY THE CUSTOMER IN ACCORDANCE WITH NATIONAL AND LOCAL ELECTRICAL CODES.
 2. REMOVE THE JUMPER FROM TERMINALS 16 AND 17 AND INSTALL THE NORMALLY CLOSED EMERGENCY STOP CONTACTS, IF APPLICABLE.
- 2 CUT WIRE JUMPER ADJACENT TO THE TERMINAL 1 ON ZONE SENSOR WHEN OPTIONAL REMOTE SENSOR IS USED.
- 4 REFER TO ZONE SENSOR INSTALLERS GUIDE FOR ZONE SENSOR SWITCH CONFIGURATION.

Scroll Compressors

(103,151,181,200,211,240,241,300,301 Units only)

Because scroll compressors are uniquely different from traditional reciprocating compressors, their operating characteristics and requirements represents a departure from reciprocating compressor technology.

Proper phasing of the electrical power wiring is critical for proper operation and reliability of the scroll compressor.

Proper rotation of the scroll compressor must be established before the unit is started. This is accomplished by confirming that the electrical phase sequence of the power supply is correct. The motor is internally connected for clockwise rotation with the inlet power supply phased A, B, C.

Correcting Improper Electrical Phase Sequence

Proper compressor motor electrical phasing can be quickly determined and corrected before starting the unit. Use a quality instrument such as an Associated Research Model 45 Phase Sequence Indicator and follow this procedure.

1. Open the electrical disconnect or circuit protection switch that provides line power to the High Voltage Terminal Block (HTB1) in the control panel.
2. Connect the phase sequence indicator leads to the HTB1 as follows:

Phase Seq. Lead	HTB1 Terminal
Black (Phase A)	L1
Red (Phase B)	L2
Yellow (Phase C)	L3

⚠ WARNING: *Bodily injury can result from high voltage electrical components. If operating checks must be performed with the unit operating, it is the technician's responsibility to recognize these hazards and proceed safely. Failure to do so could result in severe personal injury or death due to electrical shock or contact with moving parts.*

3. Read the phase sequence on the indicator after turning power on by closing the unit disconnect switch. The "ABC" indicator on the face of the phase indicator will glow if phase is ABC.

4. If the "CBA" indicator glows instead, open the unit main disconnect and interchange any two main line leads on HTB1. re-close the unit main disconnect and recheck phasing.

5. Open units main disconnect before continuing with installation.

⚠ WARNING: *Open and lock unit disconnect switch before continuing installation. Failure to do so could result in severe personal injury or death due to electrical shock or contact with moving parts.*

6. Disconnect the phase indicator.

Note: *If a phase indicator is not available, follow the electrical phasing sequence in the cooling start-up section to insure proper compressor rotation.*

IMPORTANT: *After completion of wiring, check all electrical connections, including factory wiring within the unit, and ensure all connections are tight. Replace and secure all electrical box covers and access doors before leaving unit or connecting power to circuit supplying unit.*

After all electrical wiring is complete, SET THE ZONE SENSOR SWITCH TO THE **OFF** POSITION AND THE FAN SWITCH TO **AUTO** SO COMPRESSOR AND FAN WILL NOT RUN, and apply power by closing the system main disconnect switch. This will activate the compressor crankcase heaters. Do not change the zone sensor setting until power has been applied long enough to evaporate any liquid R-22 in the compressor. It is recommended the crankcase heaters be energized for 8 hours prior to starting.

Exception - Circuit #1 on 181 and 211 units and both circuits on the 200, 240 thru 301 units are not equipped with crankcase heaters.

Start-Up Pre-Start Quick Check List

- Is unit properly located and level with proper clearances? See Figure 1A and 1B.
- Is the duct work correctly sized, run, taped, insulated and weather proofed with proper unit arrangement? (see duct work installation)
- Is condensate line properly sized, run, trapped and pitched?
- Is the filter of the correct size and number, clean and in place?
- Is the wiring properly sized and run in according to the unit wiring diagram?
- Are all wiring connections tight including those in unit and compressor electrical boxes?
- Has the unit been properly grounded and fused with the recommended fuse size? (see wiring data)
- Is the zone temperature sensor correctly wired and in a good location?
- Have the air conditioning systems been checked at the service ports for charge and leak tested if necessary?
- Does the condenser fan and indoor blower turn freely without rubbing and are they tight on the shafts?
- Has the indoor blower speed been determined and the proper speed been set? (see air flow performance data)
- Has all work been done in accordance with applicable local and national codes?

[] Are all covers and access panels in place to prevent air loss and safety hazards?

⚠ WARNING: *Bodily injury can result from high voltage electrical components. If operating checks must be performed with the unit operating, it is the technician's responsibility to recognize these hazards and proceed safely. Failure to do so could result in severe personal injury or death due to electrical shock or contact with moving parts.*

Power-up Initialization

The "initialization" by the Unitary Control Processor (UCP) occurs each time the system is powered-up. The UCP performs internal self-diagnostics checks, which include identifying the equipment components of its system, and the configuring of itself to that system. It also checks itself to be sure it is functioning correctly. On units with the optional economizer, the damper is driven open for 15 to 20 seconds and then fully closed for 90 seconds to calibrate itself. The UCP system indicator LED is turned to "ON" within one second of start-up if operation is correct.

The Unitary Control Processor (UCP) switches are factory set to provide comfort for most applications. Control cycles may be adjusted as indicated in the table below. These switches function similar to the heat anticipator adjustment in conventional thermostats.

Unitary Control Processor (UCP) Switch Settings for Cycle Timing

Switch 1	Switch 2	Cycle Time
OFF	OFF	NORMAL (Factory Setting)
OFF	ON	LONGER
ON	OFF	SHORTER
ON	ON	*SPECIAL

* Special applications, where very short cycles are necessary to prevent excessive temperature swings.

Starting the Unit in the Heating Mode

Check to ensure all grilles and registers are open and all unit access doors are closed before start-up.

Place the zone system switch in the heat position.

Position the heating setpoint approximately 10 degrees above room temperature and place the fan switch in "Auto" or "On" position.

Turn on main power supply.

Note: *To bypass time delays, and verify the operation of this unit from the roof, use the Test mode procedure on page 3 and 4 of this manual.*

Heating Shut-down

To exit the test mode, disconnect unit power for 3-5 seconds and reapply. When running the unit using the zone sensor as the control, position the selector switch at "Off". There will be a delay of 60 seconds before the unit shuts down in this setting.

Starting The Unit In The Cooling Mode

IMPORTANT NOTE: *Before starting the system in the cooling cycle, turn the zone sensor switch to "off" and close the unit disconnect switch. This procedure energizes the compressor crankcase heaters, vaporizing any liquid refrigerant in the crankcase. This is a precaution against foaming at start-up, which could damage the compressor bearings. Allow the heater to operate for a minimum of eight hours.*

Exception - Circuit #1 on 181 and 211 units and both circuits on the 200, 240 thru 301 units are not equipped with crankcase heaters.

Electrical Phasing (Scroll Compressors) If compressor electrical phasing is incorrect, compressor and indoor fan will operate in reverse, several symptoms will be apparent.

Compressors will draw low current.

Suction and discharge pressure will change very little.

A slight rattling or rumbling sound may be apparent.

Unit will not cool

Indoor fan (evaporator) will run backwards

If allowed to run backward for an extended period (5 minutes), the motor windings will overheat and cause the compressor to cycle on its thermal protector and the oil will be pumped out of the compressor.

To correct the rotation, open unit disconnect and interchange any two of the line wires at the high voltage terminal block, in the control box.

⚠ WARNING: *Open and lock unit disconnect switch before continuing installation. Failure to do so could result in severe personal injury or death due to electrical shock or contact with moving parts.*

Verify that the unit airflow rate is adjusted according to information provided in "Determining Evaporator Fan Adjustment" section of this manual.

Note: *See "Sequence of operation" in the unit Service Facts for a complete description of cooling operating sequence.*

To start the unit in the cooling mode, Close unit disconnect switch and set the zone sensor system switch to COOL and move the cooling setpoint approximately 10 degrees below room temperature. There will be a delay of up to 5 minutes before the unit will start automatically.

To bypass time delays, and verify the operation of this unit from the roof, use the "Test mode procedure" on page 3 of this manual.

Operating Pressures

After the unit has operated in the cooling mode for a short period of time, install pressure gauges on the gauge ports of the discharge and suction line valves.

Note: Always route refrigerant hoses through the port hole provided and have compressor access panel in place.

Check the suction and discharge pressures and compare them to the normal operating pressures provided in the unit's Service Facts.

Note: Do not use pressures from Service Facts to determine the unit refrigerant charge. The correct charge is shown on the unit nameplate. To charge the system accurately, weigh the charge.

Voltage

With the compressor operating, check the line voltage at the unit. The voltage should be within the range shown on the unit nameplate. If low voltage is encountered, check the size and length of the supply line from the main disconnect to the unit. The line may be undersized for the length of the run.

Cooling Shut Down

To exit the test mode, disconnect unit power for 3-5 seconds and reapply. When running the unit using the zone sensor as the control, position the selector switch at "Off". There may be a delay of up to 3 minutes before compressors shut down and an additional 1 minute before the fan shuts down in this setting.

Do not de-energize main power disconnect except when unit is to be serviced. Power is required to keep air conditioning compressor crankcase warm and boil off refrigerant in the oil.

Exception - Circuit #1 on 181 and 211 units and both circuits on the 200, 240 thru 301 units are not equipped with crankcase heaters.

Compressor Overload Protection

Important: Circuit #1 on the 181 and 211 units and both circuits of the 200,240,241,300 and 301 are equipped with external compressor overload protection. When an overload is detected the breaker(s) will trip and the UCP will lock out the compressor(s). When this happens, the breaker(s) and the UCP must be reset.

To reset the breaker(s), open and lock unit disconnect.

Remove the compressor access panel. It is not necessary to remove the control box cover. To reset the breaker, reset toggle handle. Replace the compressor access panel.

Close unit disconnect switch to resume normal operations, doing this will reset the UCP.

Close unit disconnect switch to resume normal operations, doing this will reset the UCP.

(EDC) Evaporator Defrost Control

During low ambient operation (below 55 degree F for single condenser fan units, and below 40 degree F for dual condenser fan units) compressor run time is accumulated by the UCP. When compressor run time reaches approximately 10 minutes, an evaporator defrost cycle is initiated. The defrost cycle lasts approximately 3 minutes.

During a defrost cycle, The compressor(s) are turned off and the indoor motor continues to run. After completing the defrost cycle the unit returns to normal operation, and the compressor run time counter is reset to zero.

Economizer operation is not affected by a defrost cycle.

Final Installation Checklist

- Does unit run and operate as described in the "Sequence of Operation" in the unit Service Facts?
- Is the condenser fan and indoor blower operating correctly, with proper rotation and without undue noise?
- Is the compressor operating correctly and has the system been checked with a charging chart?
- Have voltage and running currents been checked to determine if it is with limits?
- Have the air discharge grilles been adjusted to balance the system?
- Has the ductwork been checked for air leaks and condensation?
- Has the heating air temperature rise been checked?
- Has the indoor airflow been checked and adjusted if necessary?
- Has the unit been checked for tubing and sheet metal rattles and are there unusual noises to be checked?
- Are all covers and panels in place and properly fastened?
- Has the owner or maintenance personnel been given this manual, warranty, and been instructed on proper operation and maintenance?

Routine Maintenance by Owner

You can do some of the periodic maintenance functions for your unit yourself; this includes replacing (disposable) or cleaning (permanent) air filters, cleaning unit cabinet, cleaning the condenser coil, and conducting a general unit inspection on a regular basis.

Season Maintenance - Cooling

To keep the unit operating safely and efficiently, the manufacturer recommends that a qualified serviceman check the entire system at least once each year, or more frequently if conditions warrant.

Examine these areas of unit:

1. Filters (for cleaning or replacement)
2. Motors and drive system components

3. Economizer gaskets (for possible replacement)
4. Condenser coils (for cleaning)
5. Safety Controls (for mechanical cleaning)
6. Electrical components and wiring (for possible replacement or connection tightness)
7. Condensate drain (for cleaning)
8. Inspect the unit duct connections to ensure they are physically sound and sealed to the unit casing.
9. Inspect the unit mounting support to see that it is sound.
10. Inspect the unit to ensure there is no obvious deterioration.

Season Maintenance - Heating

Complete the unit inspections and service routines described below at the beginning of each heating season.

⚠ WARNING: *To prevent injury or death due to electrical shock of contact with moving parts, lock unit disconnect switch in open position before servicing unit.*

⚠ WARNING: *To prevent an explosion and possible injury, death and equipment damage, do not store combustible materials, gasoline or other flammable vapors and liquids near the unit.*

- [] Inspect the control panel wiring to verify that all electrical connections are tight, and that wire insulation is intact.

The following warning complies with State of California law, Proposition 65.

⚠ WARNING: *This product contains fiberglass wool insulation! Fiberglass dust and ceramic fibers are believed by the state of California to cause cancer through inhalation. Glasswool fibers may also cause respiratory, skin, or eye irritation.*

PRECAUTIONARY MEASURES

- * Avoid breathing fiberglass dust.
- * Use a NIOSH approved dust/mist respirator.
- * Avoid contact with the skin or eyes. Wear long-sleeved, loose-fitting clothing, gloves, and eye protection.
- * Wash clothes separately from other clothing: rinse washer thoroughly.
- * Operations such as sawing, blowing, tear-out, and spraying may generate fiber concentrations requiring additional respiratory protection. Use the appropriate NIOSH approved respirator in these situations.

First Aid Measures

- Eye Contact** Flush eyes with water to remove dust. If symptoms persist, seek medical attention.
- Skin Contact** Wash affected areas gently with soap and warm water after handling.

**LIMITED WARRANTY
CENTRAL AIR CONDITIONER
TCC, TCD, TCH and TCM
Models Less than 20 Tons
(Parts Only)**

This warranty is extended by American Standard Inc., to the original purchaser and to any succeeding owner of the real property to which the **Central Air Conditioner** is originally affixed, and applies to products purchased and retained for use within the U.S.A.

If any part, including the indoor and outdoor coil, of your **Central Air Conditioner** fails because of a manufacturing defect within one year from the date of original purchase, Warrantor will furnish without charge the required replacement part. **Any local transportation, related service labor, diagnosis calls, refrigerant and related items are not included.**

In addition, if the sealed motor-compressor fails because of a manufacturing defect within the second through fifth year from the date of original purchase, Warrantor will furnish without charge the required replacement compressor*. **Any local transportation, related service labor, diagnosis calls, refrigerant and related items are not included.**

This warranty does not cover failure of your **Central Air Conditioner** if it is damaged while in your possession or if the failure is caused by unreasonable use. In no event shall Warrantor be liable for incidental or consequential damages. **In no event shall any implied warranty of merchantability or fitness for use exceed the term of the limited warranty stated above.**

Some states do not allow limitations on how long an implied warranty lasts, so the above limitation may not apply to you. Some states do not allow the exclusion or limitation of incidental or consequential damages, so the above limitation or exclusion may not apply to you. This warranty gives you specific legal rights, and you may also have other rights which vary from state to state.

Parts will be provided by our factory organization or an authorized service organization in your area. All you need do is look us up in the yellow pages or write to the address given below. If you wish further help or information concerning this warranty, contact:

Manager - Product Service
American Standard Inc.
Clarksville, TN 37040-1008

American Standard Inc;
The Trane Co.
Clarksville, TN 37040-1008
Warrantor

GW-511-4090

*Optional extended sixth (6th) through tenth (10th) year limited warranty for the compressor is available for most models.

* * * * *

IMPORTANT NOTE: For warranty on products purchased for use outside the U.S.A., contact your local sales representative.

WARRANTY AND LIABILITY CLAUSE

COMMERCIAL EQUIPMENT

RATED 20 TONS AND LARGER AND RELATED ACCESSORIES

PRODUCTS COVERED - This warranty* is extended by American Standard Inc. and applies only to commercial equipment rated 20 Tons and larger and related accessories.

Warrantor warrants for a period of 12 months from initial start-up or 18 months from date of shipment, whichever is less, that the products covered by this warranty (1) are free from defects in material and manufacture and (2) have the capacities and ratings set forth in catalog and bulletins; provided, that no warranty is made against corrosion, erosion or deterioration. Warrantor's obligation and liabilities under this warranty are limited to furnishing replacement parts. Warrantor shall not be obligated to pay for the cost of lost refrigerant. No liability whatever shall attach to warrantor until said products have been paid for and then said liability shall be limited to the purchase price of the equipment shown to be defective.

THE WARRANTY AND LIABILITY SET FORTH HEREIN ARE IN LIEU OF ALL OTHER WARRANTIES AND LIABILITIES, WHETHER IN CONTRACT OR IN NEGLIGENCE, EXPRESS OR IMPLIED, IN LAW OR IN FACT, INCLUDING IMPLIED WARRANTIES OF MERCHANTABILITY AND FITNESS FOR PARTICULAR USE, IN NO EVENT SHALL WARRANTOR BE LIABLE FOR ANY INCIDENTAL OR CONSEQUENTIAL DAMAGES.

Manager - Product Service
American Standard Inc.
Clarksville, Tn 37040-1008

PW-215-2688

*Optional Extended Warranties are available for compressors and heat exchangers of Combination Gas-Electric Air Conditioning Units.

